



WATER SOFTENER SYSTEM 95F SERIES TECHNICAL BULLETIN

Model Number	Cubic Ft. Resin Per Each Tank/Total	Grains Capacity Per lbs. Salt				Service Flow GPM		Back Wash GPM	Lbs. Salt (Storage)	Lbs. Ship Weight (Approx)
		Economy		Maximum		Cont.	Peak			
		Grains 000s/lbs.		Grains 000s/lbs.						
		Per Resin Tank	Total/Day	Per Resin Tank	Total/Day					
95F 120	4.0/8.0	80/24	320/100	120/60	480/240	30	41	7.0	400	800
95F 150	5.0/10.0	100/30	400/120	150/75	600/300	35	46	12.0	500	1100
95F 200	6.7/13.4	134/41	536/164	200/100	800/400	32	43	12.0	500	1170
95F 240	8.0/16.0	160/49	640/196	240/120	960/480	39	51	15.0	800	1700
95F 300	10.0/20.0	200/61	800/244	300/150	1200/600	37	48	15.0	800	1820

Protection:

The build-up of hard water scale significantly reduces efficiency and can damage critical components. The Trusco water softener is designed to maximize removal of harmful calcium and magnesium ions that precipitate from hard water. Properly selected and installed, a Trusco water softener will maintain your investment for the duration and ensure high efficiencies while minimizing costly repairs.

Applications:

- Apartment buildings
- Commercial buildings
- Condominiums
- Factories
- Hospitals
- Laundries
- Motels/Hotels
- Nursing/Rest Homes
- Office buildings
- Restaurants
- Schools
- Car Washes
- Boiler pre-treat
- And more!

Features:

- Continuous soft water with alternating twin tank design.
- Regeneration based on water use to minimize salt usage and cost associated with operation.
- Soft water regeneration for added performance.
- Non-corroding polyglass resin tank and high density polyethylene brine tank.
- Dual guard brine operators for prevention of brine tank overflow and accurate brine selection.
- Adjustable regeneration cycles for efficient water usage.
- High capacity, long life cation exchange resin.
- Pre-plumbed manifolds reduce field installation expense.



95F SERIES

Operating Specifications:

- Pressure; 25 PSI to 125PSI
- Temperature; 100°F Maximum
- Electrical; 24v, 110v, 220v-50Hz, 60Hz
- 5 Cycle regeneration (Backwash, brine draw, slow rinse, fast rinse, and service).

Warranty:

- 5 years against defect in residential tanks.
- 5 years against defect in commercial tanks.
- 5 years against defect in control valve.
- 1 year against defective material, workmanship on remaining supporting parts.



COVER REMOVED

95F SERIES WATER SOFTENER DIMENSIONS

	A	B	C	D	E	F	G	H	I
Model Number	Resin Tank Diameter	Resin Tank Height	Brine Tank Diameter	Brine Tank Height	Inlet Outlet Height	Inlet Outlet NPT	Overall Height	Overall Length	Width of Resin Tanks Combined
95F 120	16"	65"	24"	41"	67"	1.5"	74"	62"	34"
95F 150	22"	60"	24"	50"	62"	1.5"	70"	74"	45"
95F 200	22"	60"	24"	50"	62"	1.5"	70"	74"	47"
95F 240	24"	71"	30"	48"	73"	1.5"	82"	85"	50"
95F 300	24"	71"	30"	48"	73"	1.5"	82"	85"	50"

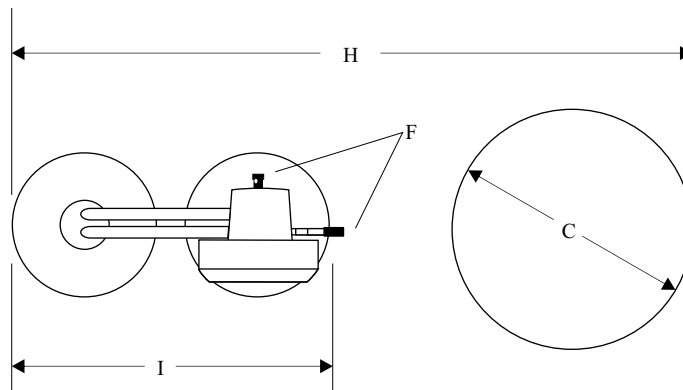
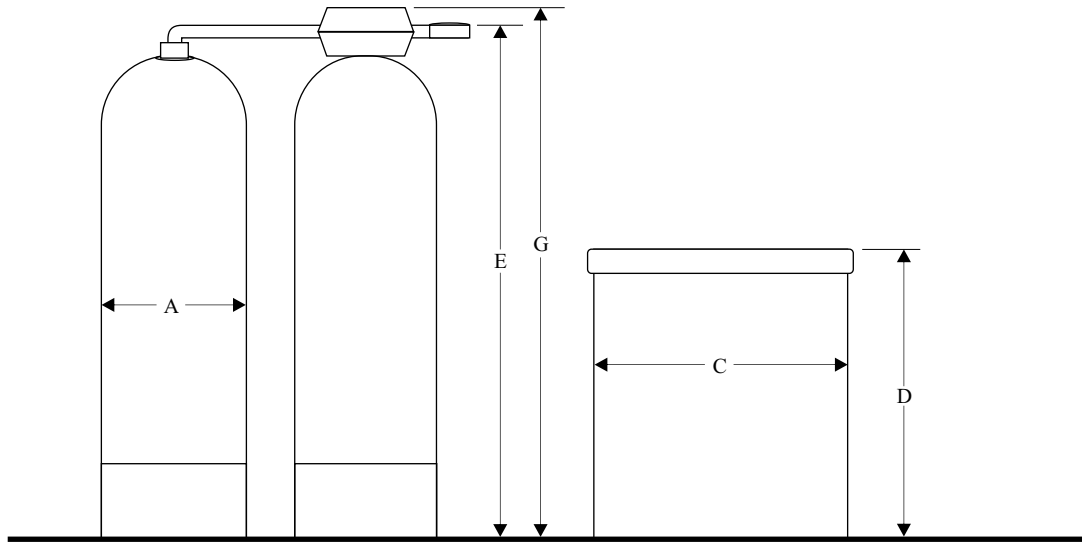

Distributed By:



3611 3 Mile Road NW
Grand Rapids, MI 49534-1231
1-800-446-7267